

# Diamond Wire Saw 42"

**Underwater Cutting Solutions** (UCS) are a leading offshore contractor specialising in the cutting of submarine & Topsiside pipelines and structures using a range of purpose designed tools and techniques. UCS also provides a range of dredging equipment for diver and ROV use.

UCS cutting systems can be provided around the world\* with their experienced crews either on stand-by contingency basis or on a rapid deployment

## Features & Benefits

- ✓ **Fast and Accurate Cut**
- ✓ **7" to 42" Capacity**
- ✓ **Self-regulating feed**
- ✓ **Superior Performance**



The UCS Diamond Wire Saw system has been developed to cut tubulars up to 42" diameter, The feed mechanism is automatically regulated by the load on the cutting wire, thus minimising the probability of broken wires during cutting. This unit will provide a fast and accurate cut

<b>Cutting Capacity</b>	7" (100mm) to 42" (762mm) without the need for reconfiguration.		
<b>Hydraulic Requirements</b>	60 l/min (15.87 usgpm) at 210 Bar (3045 psi)		
<b>Hydraulic Oil</b>	ISO VG32 or Equivalent		
<b>Blade Speed</b>	Variable to 22m/s (69ft/s)		
<b>Typical Cutting Speed</b>	4 to 20 mm/min		
<b>Mass (approx)</b>	550kg (1212.5 lb)		
<b>Jaw width Open</b>	1108mm (43")		
<b>Dimensions</b>	<b>Length</b>	<b>Width</b>	<b>Height</b>
	1572mm 61.9"	660mm 26"	2234mm 88"

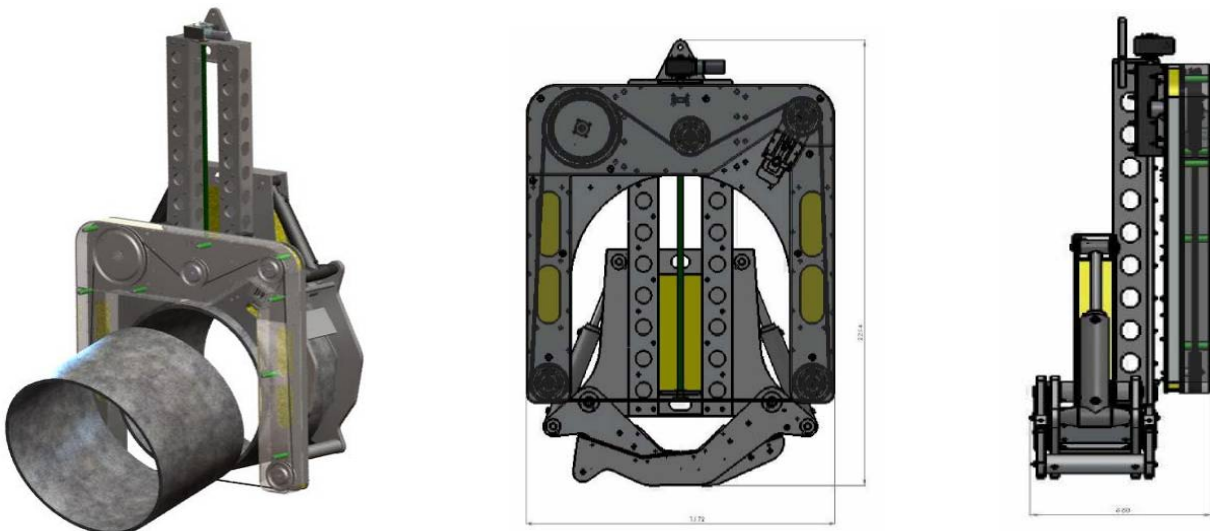

\* Due to the existence of European patent number 0540834, Norwegian patent number 180185 and Italian patent number 1253716, we are unable to provide this service or tender for these services in the following jurisdictions: Germany, Denmark, France, The UK, The Netherlands, Norway and Italy until the expiry of the patents on 14th August 2012 (31st November 2011 in relation to Italy\*)

## Underwater Cutting Solutions Limited

Units 8/8a Inverurie Business Park, Souterford Avenue, Inverurie, Aberdeenshire  
AB51 0ZJ. UK

Tel: +44 (0)467 622212 Email: [admin@ucsltd.com](mailto:admin@ucsltd.com)