

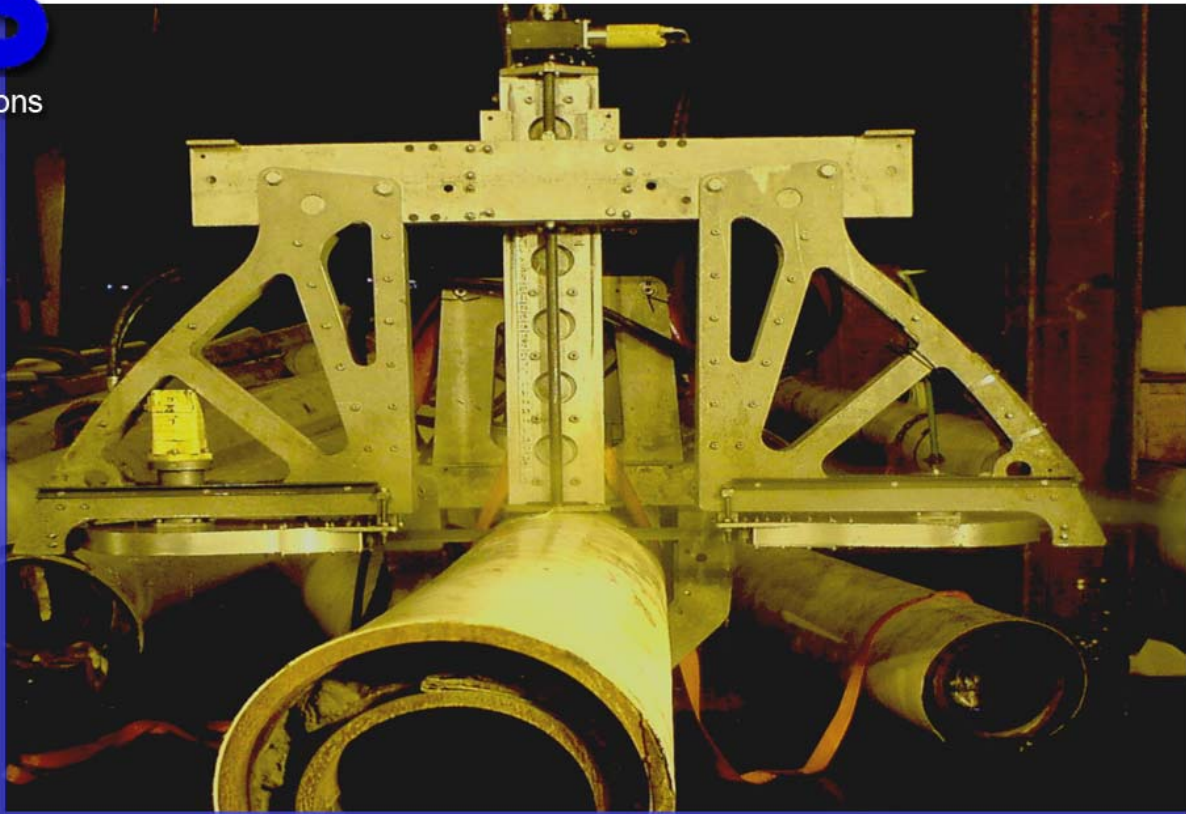

Underwater Cutting Solutions



Features & Benefits

Patented Cutting Technique

Fast & Accurate Cut

Proven Reliability

4" to 30" Capacity

30mm Coupon
Removed for
Inspection

Diver or ROV
Operation

Dual Cut Bandsaw

Underwater Cutting Solutions (UCS) are a leading offshore contractor specialising in the cutting of submarine & Topside pipelines and structures using a range of purpose designed tools and techniques. UCS also provides a range of dredging equipment for diver and ROV use.

UCS cutting systems can be provided around the world with their experienced crews either on stand-by contingency basis or on a rapid deployment

The system uses standard heavy-duty band saw blades to carry out two cuts simultaneously, each cut in the opposite direction, approximately 30 mm apart.

The reaction loads generated by each of the simultaneous cuts are cancelled out, resulting in a very smooth, vibration free and reliable cut. On completion of the cut, a 30 mm wide 'coupon' falls out, leaving a gap between the two ends of the pipe. This system provides fast and accurate vertical, horizontal and diagonal cuts.

This system can be supplied with diver operating control handles or with ROV hot stabs and grab arm.

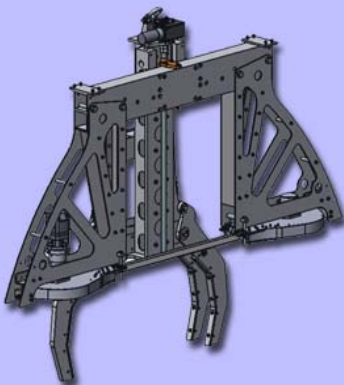

Innovation in Subsea Solutions

Dual Cut Bandsaw Specification



VIEW ON END

ELEVATION ON 30" PIPE

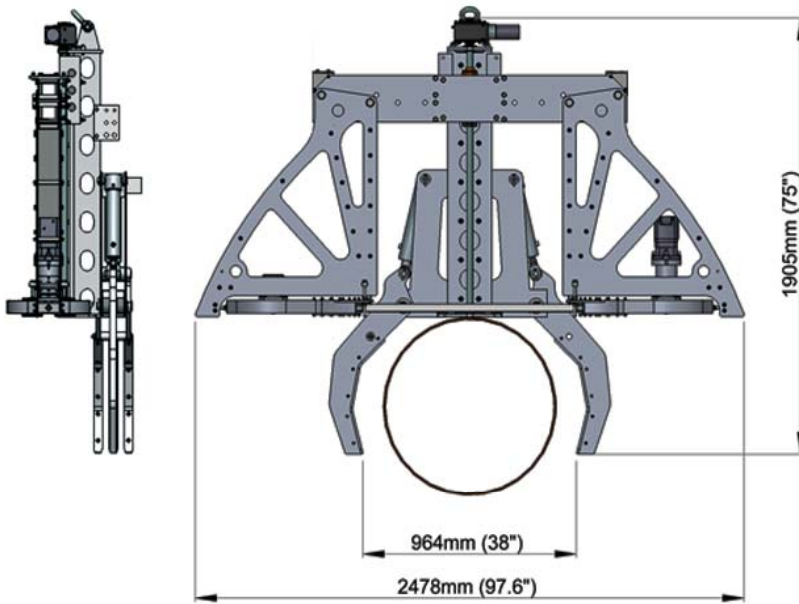

Functionality

The UCS Patented Dual Cut BandSaw incorporates three basic functions.

Main Clamp - Attaches the saw securely to product

Saw Motor - Drives the Saw blade

Feed Motor - Advances the blade through product at a controlled rate.

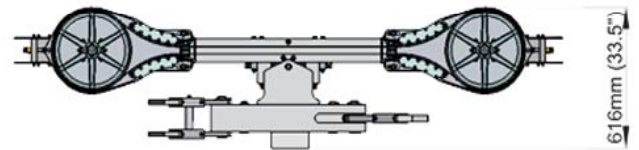

VIEW ON UNDERSIDE

Cutting Capacity	100mm (4") to 762mm (30")		
Hydraulic Requirement	40 l/min @ 210 Bar		
Hydraulic oil type	ISO VG32 or Equivalent		
Max Carriage Speed	60mm/min (2.3" / min)		
Typical Cutting Speed	4mm/min (0.16") to 20mm / min (0.79")		
Mass In Air	250kgs (551lbs) - 300kgs (661lbs) with buoyancy		
Mass in Water	200kgs (441lbs) Neutral with Buoyancy		
Clamp Jaw Open	964mm Max (38")		
Dimensions	Length	Width	Height
	2478mm	850mm	1951mm
	97.6"	33.6"	76.8"

